

Parklex

Polígono Alkaiaga, c/ Baldrún - 31780 Bera - Navarra - Spain

Tel. +34 948 625 045 – parklex@parklex.com

www.parklex.com

The latest version of the Technical Guide is available on the Parklex website.

1. About Facade

1.1. Product features	9
1.1.1. Product quality and certificates	9
1.1.2. Environmental sustainability	9
1.1.3. Technical datasheet	10
1.2. Transport	11
1.3. Storage	11
1.4. Handling	12
1.4.1. Cutting	12
1.4.2. Drilling	12
1.4.3. Machining	12
1.5. Cleaning and maintenance	13
1.5.1. Cleaning	13
1.5.2. Maintenance	13
1.5.3. Repair	13
1.6. Information for removal	14
1.6.1. Waste management information	14

2. General Instructions

2.1. Humidity and temperature	18
2.2. Expansion joints	19
2.3. Choosing panel thickness	19
2.4. Three support points	20
2.5. Counter-sunk screws not allowed	20

3. Installation system on ventilated façade

3.1. Ventilated chamber	24
3.2. Substructure	26
3.3. Fixing systems	27
3.3.1. Exposed screw or rivet fixing	27
3.3.2. Fixing with plugs	31
3.3.3. Hidden fixing with bracket hanging system	32
3.3.4. Hidden fixing with an adhesive system	35
3.3.5. Hidden fixing with overlapping slats	36
3.4. Installation details	38
3.4.1. Window details	38
3.4.2. Corner details	39

4. Louvre installation system

4.1. Static louvres	42
4.1.1. Substructure	43
4.1.2. Substructure installation	43
4.1.3. Supporting clip installation	44
4.1.4. Louvre installation	45

5. Dropped ceiling installation system

5.1. Fixing the dropped ceiling	48
5.2.1. Screw or rivet fixing	48
5.2.2. Fixing with plugs	49
5.2.3. Hidden fixing with bracket hanging system	49

6. Installation system in curves

6.1. Panel curving	52
6.2. Pre-curved panels	53
6.3. Pre-curved panel installation	53
6.3.1. Exposed screw or rivet fixing	53
6.4. Technical datasheet	54

1. About Facade

Facade construction

High-density stratified panel with natural timber veneer for outdoor use

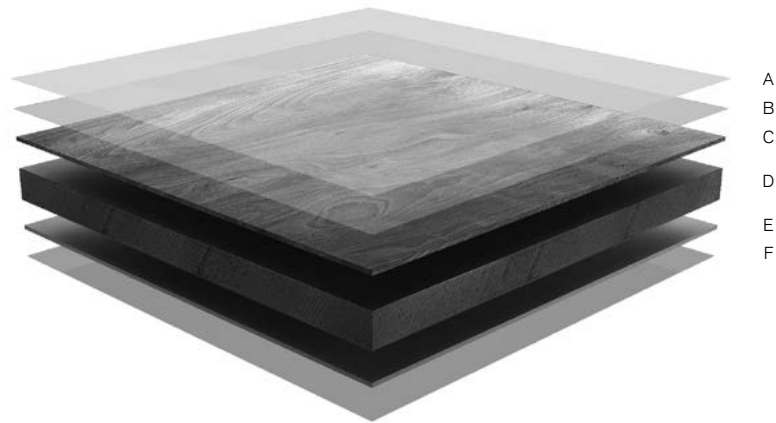

A
PVDF Antigrffiti overlay

B
Everlook®

C
Natural timber veneer

D
HPL core

E
Natural timber veneer

F
Balancing film

1.1. Product features

Facade is a high-density timber faced panel, manufactured with a core of paper fibres treated with thermosetting resins. These are compressed at a high temperature and pressure and protected by an exterior coating highly resistant to UV radiation and weathering. Facade panels include Everlook®, a component introduced into the wood to provide outstanding life-cycle benefit in terms of colour stability, in all climatic conditions with no varnish need at all over the years. It also allows the development of new finishes to our range of timber veneers.

The entire Parklex range is manufactured from natural wood materials, with each panel reflecting unique characteristics such as changes in tone, colour and highlights, with grain and knots. This provides surfaces with an appearance that only products manufactured in natural wood can offer.

1.1.1. Product quality and certificates

Parklex products may be installed in both internal and external environments. They are subject to constant wear from the sun, humidity and abrasion in extreme traffic areas. For this reason, a great deal of effort and investment in R+D is made, ensuring the durability and stability of Parklex coverings. Facade panels are subjected to rigorous testing both at our in-house R+D Department as well as independent, accredited laboratories throughout the world. Our commitment to quality ensures the outstanding performance of our products. Facade complies with (and often exceeds) the standards laid down by international certification schemes, including DIT plus (Spain), AVIS Technique (France), Zulassung (Germany), ESR (U.S.) and BBA (United Kingdom), as well as other national schemes throughout the world.

Body	Certificate	Fastening System	Panel Type	Panel Thickness
IETcc	European Technical Assessment ETA-13/0627	Exposed: wood, aluminum or galvanised steel profiles	FACADE F	6-14mm
		Hidden: aluminum profiles		10-14mm
IETcc	Ditplus 523p-16	Exposed: wood, aluminum or galvanised steel profiles	FACADE S FACADE F	6-14mm
		Hidden: aluminum profiles		10-14mm
CSTB	Avis Technique 2/11 1474	Parklex Facade sur ossature métallique	FACADE S FACADE F	6-14mm
		Parklex Facade sur ossature aluminium en zones sismiques		6-10mm
DiBt	Allgemeine bauaufsichtliche Zulassung 33.2-626	Exposed: wood or aluminum profiles	ProdEX IGN	8-12mm
BBA	Agrément Certificate 08/4573	Exposed: wood, aluminum or galvanised steel profiles	FACADE S FACADE F	6-14mm

Parklex gives a 10-year* guarantee for this product. Panels not vertically installed will have a reduced guarantee of 5 years.

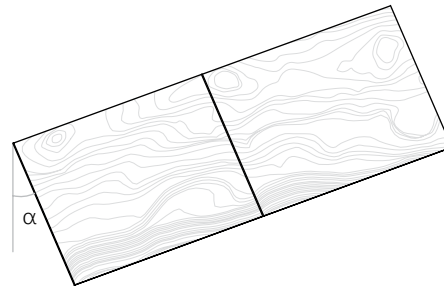

Max. α for 10 years warranty ≤ 30°

If α > 30° = 5 years warranty

* The general terms and conditions of the guarantee may be changed without prior warning.

1.1.2. Environmental sustainability

Being acutely aware of the importance of caring for our environment with responsible, sustainable production, Parklex has opted for an Environmental Sustainability strategy. Concerned about the environmental behavior of the product, its LCA (life cycle analysis) has been performed. Based in this analysis, the Carbon Footprint value and some Ecolabels (FDES and EPD) have been obtained.

Fiche de Déclaration Environnementale et Sanitaire selon NF P 01_010

ENVIRONMENTAL PRODUCT DECLARATION OF "Parklex FACADE" by The International EPD® System.

1.1.3. Technical datasheet

(See next page)

Tests	Standard	Property or attribute	Measurement unit	Result	
				Parklex Facade S (Standard) Rev: 09 (02.2013)	Parklex Facade F (Fireproof) Rev: 10 (04.2013)
1. Inspection requirements					
Colour, pattern and surface finish	EN 438-8 Part 5.2.2.3	Due to the fact that wood is a natural product, each veneer may be considered as unique. Colour and structure differences are considered as normal. Singularities such as knots and resin inclusions are not considered as defects, but as a part of the décor. There are differences in light fastness performances depending on the wood species and the source of the wood.			
2. Dimensional tolerances					
Thickness (t)	EN 438-2 Part 5	6,0 ≤ t < 8,0 8,0 ≤ t < 12,0 12,0 ≤ t < 16,0 16,0 ≤ t < 20,0 20,0 ≤ t < 25,0	mm	± 0,40 ± 0,50 ± 0,60 ± 0,70 ± 0,80	
Flatness (f)	EN 438-2 Part 9	6,0 ≤ t < 10,0 10,0 ≤ t	mm/m	5,0 3,0	
Length and width	EN 438-2 Part 6	–	mm	+10 / -0	
Edge straightness	EN 438-2 Part 7	–	mm/m	1,5	
Edge squareness	EN 438-2 Part 8	–	mm/m	1,5	
3. Physical properties					
Dimensional stability at elevated temperatures	EN 438-2 Part 17	Cumulative dimensional change (t ≥ 6mm)	% max Longrain % max Crossgrain	0,3 0,6	
Resistance to impact with large diameter ball	EN 438-2 Part 21	Maximum height for which no visible surface cracking or imprint greater than 10mm (t ≥ 6mm)	mm	≥ 1.800	
Tensile strength	EN ISO 527-2	Longrain Crossgrain	MPa	≥ 60	
Determination of graffiti resistance	ASTM D 6578:2000	Cleanability level	Permanent blue marker Spray red paint Wax black crayon Water based black marker	4 4 1 2	
4. Weather resistance requirements					
Resistance to UV light	EN 438-2 Part 28 Rating according to EN 20105 – A02	Contrast Aspect	Grey scale rating Rating	≥ 3 ≥ 4	
Resistance to artificial weathering (including light fastness)	EN 438-2 Part 29 Rating according to EN 20105 – A02	Contrast Appearance	Grey scale rating Rating	≥ 3 ≥ 4	
5. CE Safety requirements					
Water vapour permeability	EN 438-7 Part 4.4	Wet cup method Dry cup method	μ	110 250	
Resistance to fixings	EN 438-7 Part 4.5	Screw holding value t ≥ 6mm Screw holding value t ≥ 8mm Screw holding value t ≥ 10mm	N	> 2.000 > 3.000 > 4.000	
Flexural strength	EN ISO 178	Longrain Crossgrain	MPa	≥ 80 ≥ 80	
Flexural Modulus	EN ISO 178	Longrain Crossgrain	MPa	≥ 9.000 ≥ 9.000	
Thermal resistance/Conductivity	EN 12664	Thermal conductivity (λ)	W/m K	0,266	0,281
Resistance to climatic shock	EN 438-2 Part19	Appearance Flexural strength Elastic modulus	Rating Ds Rating Dm Rating	≥ 4 ≥ 0,95 ≥ 0,95	
Density	EN ISO 1.183	Density	g/cm ³	≥ 1,35	
Resistance to wet conditions	EN 438-2 Part 15	Moisture absorbed Appearance	% Rating	≤ 5 ≥ 4	≤ 8 ≥ 4
6. CE Safety requirements - Reaction to fire					
Reaction to fire	EN 13.501-1	Euroclass t ≥ 6mm Euroclass t ≥ 8mm	Classification	C-s2,d0	B-s1,d0

(1) Provided that the laminates are stored in the manner and conditions recommended by the manufacturer.

Panel measurements

Length (grain direction) x width	2440x1220mm	Thickness*	6, 8, 10, 12, 14, 18, 20 & 22mm
----------------------------------	-------------	------------	---------------------------------

* 6mm can only be used for special applications. Other thicknesses may be available upon request.

1.2. Transport

The panels must be correctly strapped down for transport, bearing in mind that they slide over each other easily and may become damaged. They must **always** be transported horizontally. The panels must never be transported loose or with broken straps. For short trips, inside workshops or at the construction site, fasten the panels using straps whilst protecting the edges in contact with the straps with cardboard protectors. Avoid the presence of rough objects or sharp edges between panels that may damage or scratch their surface. When moving panels on the same stack, lift them so that they do not scrape against each other.

Once the original packaging has been opened, we recommend that you only remove the Facade panels to be installed immediately. The remaining panels must be stored in conditions identical to those of the original packaging.

Removing the protective film

Panels for external use are covered with a protective film on their exposed side, which must be removed **immediately after** installing the panel, as prolonged exposure to the elements will cause the adhesive on the film to soil the panel.

1.3. Storage

Horizontal storage

Panels must be stored in a horizontal position, never in a vertical or inclined position. It is essential to keep them from resting on objects or debris that prevent the panels from being completely horizontal. The distance between supports must be $\leq 800\text{mm}$.

Optimal condition storage

To prevent deformation, store in a clean, dry place, protected from rain and sun. Recommended storage conditions include a Temperature of 10-25°C and a Relative Humidity of 30-70%. Climatic and humidity differences on both panel surfaces should be avoided. In cases involving the installation of panel fixings (fixing brackets for example), they must be stored face to face and rear side to rear side. Storage time should never exceed five months from the date indicated on the delivery invoice. These instructions are also valid for components.

Random panel installation

Due to being made with natural wood, the Facade panels come in different shades to one another. We therefore recommend mixing panels from different pallets (respecting the packaging requisites) to avoid undesired aesthetic effects.

For cases involving extension or similar work, we recommend that you send us a sample.

1.4. Handling

Standard requirements should be kept in mind when handling Facade panels, especially with regards to

- Dust removal.
- Dust collection.
- Fire precautions, etc.

Due to the possible presence of sharp edges, protective gloves should always be worn when handling Facade panels. Contact with dust from HPLs does not normally present a problem, although some people may be sensitive or even allergic to it.

1.4.1. Cutting

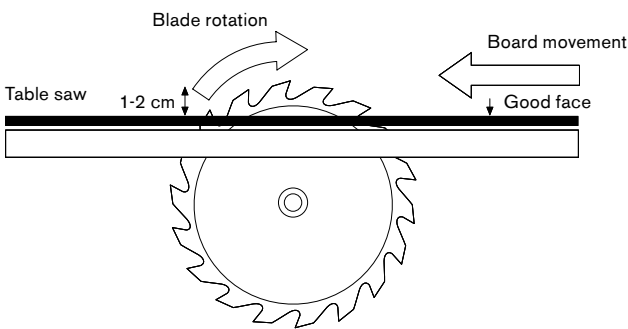

Parklex panels may be machined using conventional commercial grade carpentry machines equipped with hard metal accessories. Due to the high density of Facade, cutting speeds must be slower than those used with wood: Facade panels may be cut with stationary circular table saws or with handheld circular saws.

If many panels are to be cut, stationary table saws must be equipped with diamond-tipped accessories. If not, or if manual machines are being used, the accessories must be made from hard metal plates or “Widia” (tungsten carbon), with a hardness of K-05 and K-01.

Accessories made from high-speed steel or that contain a high level of cobalt are not recommended. Lower sharpening performance will be obtained.

The blade teeth should always enter on the panel's good face. Table saws generally have the good face pointing up, as the blade rotates with the blade cutting on the 'downstroke'. Hand held circular saws generally cut on the 'upstroke', therefore the panel should face down.

	Stationary circular table saws	Handheld circular saw
Ø	250-300mm	150-190-210mm
Teeth	60-80-96	48-64-64
Mov. speed	4-6 m/min	4-6 m/min
Turning speed	According to machine	According to machine
Type of teeth	Flat, trapezoidal tooth	Flat, trapezoidal tooth

1.4.2. Drilling

The panels must be drilled using hard metal or “Widia” tools. Supporting sheets (martyr boards) must be used under the panel in order to drill a clean hole, without 'breakout'.

- A. Good face
- B. Supporting sheet

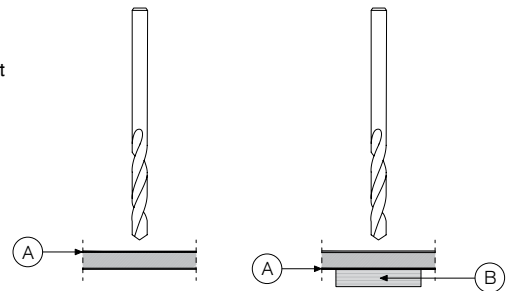

Mov. speed	4 m/min
Turning speed	2500-3500 rpm
Material	It can be drilled with conventional hard metal drill bit, but micrograin hard metal drill bit is recommended to ensure a greater number of holes with an optimum finish.

1.4.3. Machining

Water jet cut: This system is compatible with Facade panels, although it is advisable to carry out a preliminary test in order to adjust the parameters.

Laser cut: This system is not recommended for use with Facade panels given that it blackens and burns the wood veneer.

CNC: The Facade panel can be machined on CNC machining centres. The milling cutters must be perfectly sharp, with the following recommendations:

- Turning speed: 16 000 rpm
- Movement speed: 4 m/min

1.5. Cleaning and maintenance

1.5.1. Cleaning

The non-stick composition of the surface of Facade panels will allow most stains to be removed easily, with water and mild household detergents.

However, if the surface is dirty or there are traces of the adhesive of the protective film, this can be cleaned with warm water mixed with liquid detergent, using a soft and clean cloth but never rubbing the surface when dry. **Never** use abrasive detergents.

In case of stubborn stains, the surface of the panel can be cleaned with a soft cloth (not dyed), dampened with universal solvent (petroleum naphtha or white spirit). Never use cloths or sponges with abrasive cleaning or sanding agents, as they may damage the surface of the panel.

Nor harsh solvents as Acetone, Ethyl Acetate, MEK, nail polish remover, etc... should be used. They can cause permanent damage by dissolving the surface protection film partially, totally or by causing cracks, which may not be obvious at first glance. These products should also not be used at the rear side of the boards.

The surface of the panel must be dried using an absorbent, fluff-free cloth.

It is recommended to always test clean a small part of the affected area, and once the effectiveness of the procedure has been verified, proceed with the rest of the surface.

Important Note

Solvents and chemical cleaning products must be used following appropriate health and hygiene regulations at all times.

Cleaning graffiti

The specially treated non-stick surface of Facade will prevent aerosol paints from permanently adhering to the surface of the panel.. However, removal may require products specifically designed for removing this type of paint. A final cleaning with soapy water and a full rinse with clean water are recommended.

We have specific Resistance to Graffiti tests available for stains made with the following materials:

- Solvent-based: permanent blue marker and red spray paint
- Black wax
- Water-based black marker

Never use abrasive cleaning powders or pastes, which will scratch the surface.

If you would like to see the results of these tests, please request them from the Parklex sales network.

1.5.2. Maintenance

Simple cleaning of Facade panels is the only maintenance needed. The surface does not require any specific preventative treatment designed for wood.

1.5.3. Repair

There is currently no prescribed method for repairing Facade panels. In case of severe damage, affected panels must be replaced with new.

1.6. Information for removal

The main components for the Facade panels installation (aluminium, steel, timber and/or plastic) are easily separated for recycling.

1.6.1. Waste management information

The specifications that rule the production and management of waste generated in construction and demolition must be fulfilled, as well as any current local regulation.

The re-use of the Facade panels in other applications with different requirements is encouraged.

It is possible the assessment of the waste by industrial incineration.

2. General Instructions

2.1. Humidity and temperature

Facade is a high-quality construction product installed as a vertical decorative covering on the façade.

For correct panel installation it is important to follow the general installation instructions described below. This ensures optimal performance over time, which prevents premature deterioration and ensures its perfect performance.

**In the event that a Technical Document exists that applies to a specific installation system, such as the ESR (ICC) in U.S., it shall take precedence over the general recommendations described here. In addition, building insurers may also have their own applicable standards.*

Ventilated installation

For appropriate Facade panel behaviour, it is essential to maintain compensation of the temperature and humidity conditions on both panel faces, by means of an installation that allows air to circulate behind them.

Panel movement

It must be kept in mind that the Facade panels will be exposed to changing seasons over the years, and that they are composed of natural wood. Given that wood is a living material which suffers dimensional variations due to changes in humidity and temperature, it is important that the fixings allow the panels to move and that they do not block their free expansion and contraction.

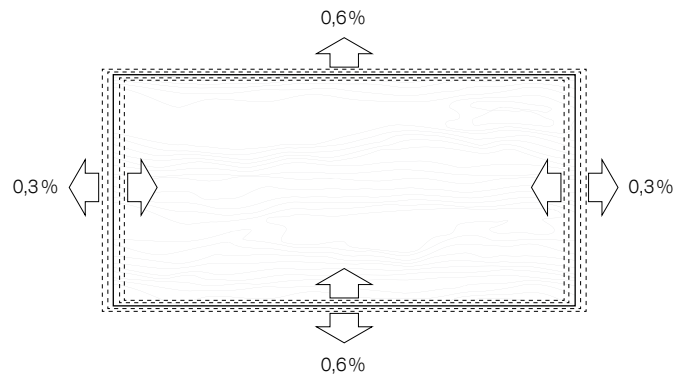

2.2. Expansion joints

It is necessary to leave expansion joints around the perimeter of all panels and where they meet with other materials to ensure they can absorb any expansion movements. The thickness of these joints depends on the panel dimensions and the façade design. As an example, for panels measuring 2440x1220mm, these joints must be **at least 6mm**. It is recommended not to seal the joints with flexible materials, as this may lead to an accumulation of dirt around the edges of the panels.

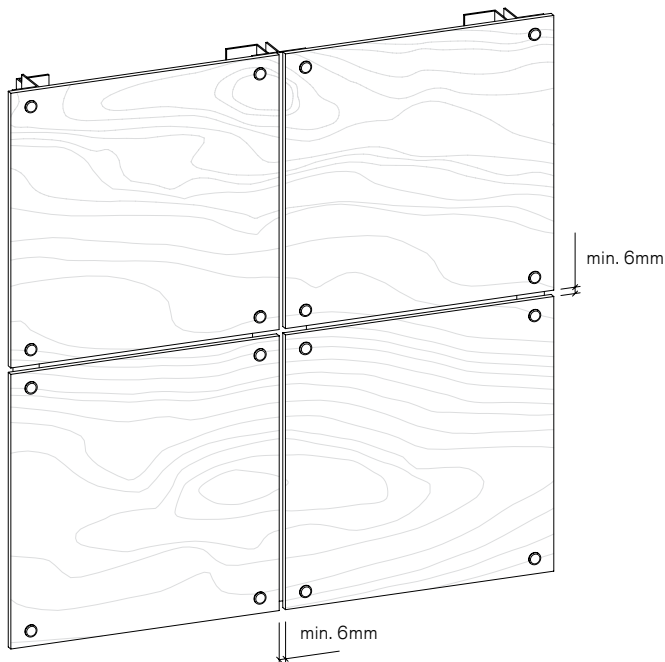

2.3. Choosing panel thickness

The required panel thickness is selected according to the element to be covered (walls, ceilings or façades). The thickness of a panel influences the distance between the supporting profiles; the greater the thickness, in general the greater the possible distance between the profiles. This may vary, depending on the specific type of installation. The ideal thickness for external facades is 8 or 10mm. Thickness of 6mm* **is not recommended**, except in very special cases.

** If you are considering the use of this thickness, it is essential to consult the technical department at Parklex.*

Facade thicknesses

6mm	
8mm	
10mm	
12mm	
14mm	
18mm	
20mm	
22mm	

2.4. Three support points

Facade panels must be fixed to at least three points of structural support*. The distances between support points depend on the mounting type and the thickness of the panel. The instructions regarding distances that come with the various, commercially available fixing systems may be followed, as long as there are at least three points of support in each direction.

* See exceptions in the table below.

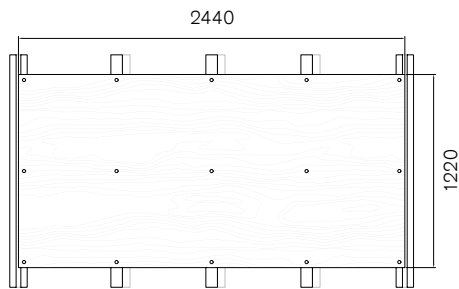

Profile distribution for 10mm Facade.

2.5. Counter-sunk head screws not allowed

Facade panel installation using counter-sunk head screws is not allowed as they do not enable free panel movement.

Exposed fixing		Hidden fixing	
2 support points	3 support points	2 support points	3 support points
100-350mm	350-600mm	150-400mm	400-600mm
<i>Exception</i>		<i>Exception</i>	

3. Installation system on ventilated façade

3.1. Ventilated chamber

For the installation of Facade panels in ventilated façade mode, the panels are installed on vertical profiles, creating an interrupted flow of air in the rear part of the panel.

Facade panels must be installed as a ventilated façade; therefore, they must be separated from the wall face by profiles, which are installed vertically, forming a chamber with a free ventilated space of ≥ 20 mm, except in those countries with specific technical documents. In the event that some type of insulation will be installed, a double-profile structure or a single-profile structure with adjustable supporting elements must be installed, ensuring that the chamber is maintained. To permit air circulation in the ventilated chamber, the air intake and output must be correctly proportioned.

Head ventilation

The ventilation at the head of the chamber must be ≥ 20 mm. This ventilation space must be left whenever there is an interruption in the face of the Facade panels.

Base ventilation

The ventilation at the base of the chamber must be ≥ 20 mm. This ventilation space must be left whenever there is a new base i.e. if the Facade panels are interrupted by windows or other elements.

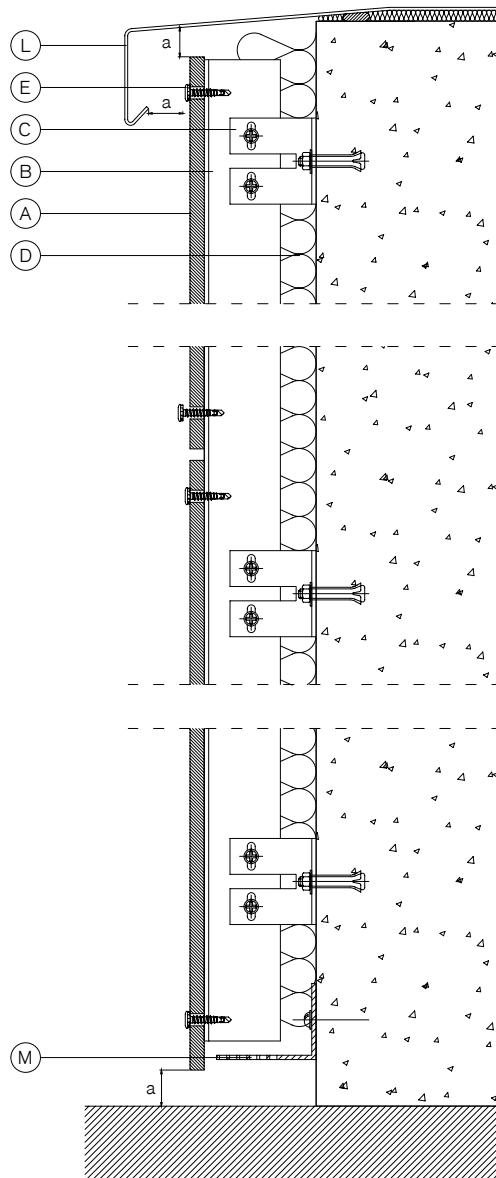

- A.** Facade panel
- B.** Metal batten
- C.** Fixing bracket
- D.** Insulation
- E.** Screw
- L.** Metal plate
- M.** Perforated profile

a ≥ 20mm (Except in those countries with specific documentation)

Permeability

Moving air diffuses water vapour from the inside out and facilitates the 'breathing' of the façade, preventing condensation from forming behind the panels.

Water protection

Moving air provides protection from the elements, because it assists in preventing rain water from infiltrating the building structure.

Thermal insulation

The load-bearing structure is insulated from the exterior structure, eliminating thermal bridges. In this manner, temperature fluctuations are reduced in the interior, leading to energy savings.

Solar protection

Thermal comfort is improved inside the building by preventing overheating in the summer, as it facilitates 'breathing' of the façade. This assists by reducing the amount of thermal energy that reaches the inside of the building. The internal structure is protected from direct radiation and from the elements.

Acoustic protection

Since this is a compound system with several layers, noise absorption is created.

3.2. Substructure

To facilitate air circulation behind the panels, a substructure of vertical profiles must be installed. The substructure must be designed according to the habitual wind load in the area and in such a way that it meets all static requirements. Account must also be taken of the façade inclination, the fastening system chosen, and the thickness and dimensions of the Facade panel being installed in order to establish the parameters applied. In addition, it must be perfectly protected against corrosion and rotting, regardless of the material or system used. The minimum support width of the profile for intermediate points is 60 mm, and 80 mm for the points where two panels meet.

Wood substructure

If the substructure is built from timber battens, they must be suitably treated. It is recommended to install PVC joints or closed-cell polyethylene foam over the exposed surfaces, as these protect, improve and extend their service life. This type of substructure may be used in dry areas, generally without frequent rainfall.

Metal substructure

If located in rainy or humid locations, it is preferable to use metal vertical profiles made from galvanized steel or aluminum. In areas that suffer obvious effects from the sea, stainless steel profiles must be used, or those made from an appropriate anodized aluminum.

Vertical alignment

It is not unusual for façades to have surface irregularities. In these cases, the use of profiles with **brackets** that allow for adjustment of the vertical alignment is recommended. The brackets are fixed to the profile with stainless steel self-tapping screws.

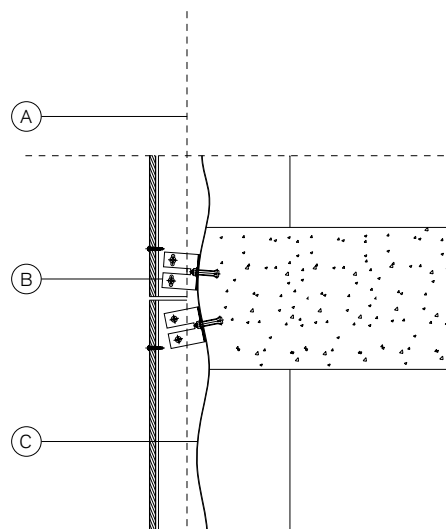

A. Line of reference
B. Bracket
C. Irregular wall face

Material	Recommended thicknesses
Steel	1,5 – 2mm
Aluminum	2 – 3 mm

3.3. Fixing systems

To install Facade panels as a ventilated façade, Parklex provides five different systems, one of which is exposed while the others are hidden, for cases where the façade design requires a surface with no screw marks.

3.3.1. Exposed screw or rivet fixing

Facade may be installed using visible mechanical fasteners, such as screws or rivets lacquered in a shade similar to the panel veneer. The panels are mounted on vertical profiles to create a ventilated chamber behind the panels. In the event that the wall is not perfectly vertically aligned, fixing brackets are used to regulate the depth of the profile installation.

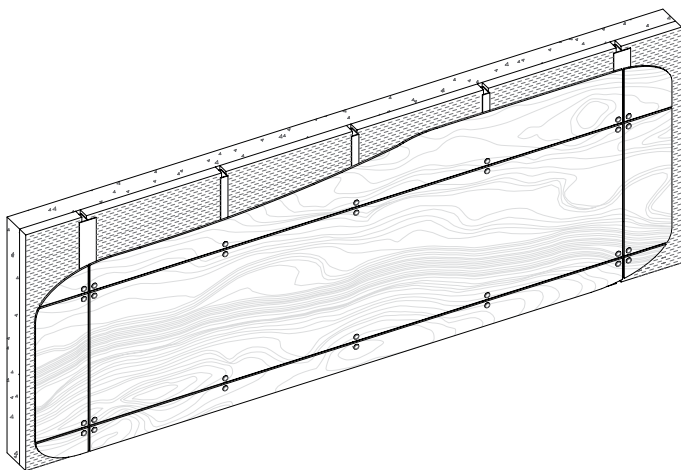

Distance between vertical profiles

Thickness	Maximum distance
8 mm	600mm
10 mm	700mm
≥12 mm	800mm

There must always be at least 3 fastening points in each direction for every panel.

Distance between fasteners

Thickness	Maximum distance
8 mm	600mm
10 mm	700mm
≥12 mm	800mm

Distance from the edges

The distance between the centre point of the screw/rivet and the panel edge must be between 20mm and 40mm.

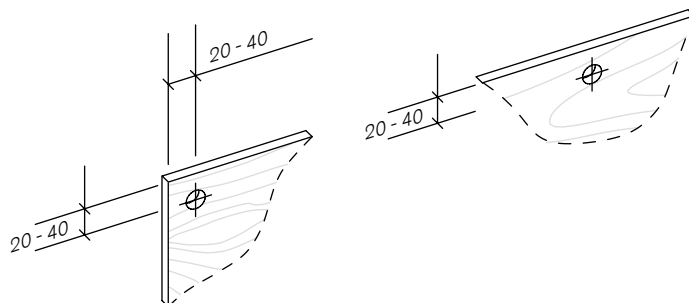

Fixed point and floating point

All mounting points for Facade panels must be floating (with a diameter of at least 3 mm larger than that of the screw or rivet; see the next chapter), except for one, which must be fixed. This is the point around which the panel will expand and contract. This fixed point must be as close as possible to the center of the panel.

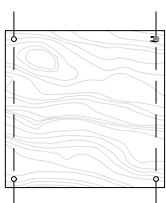
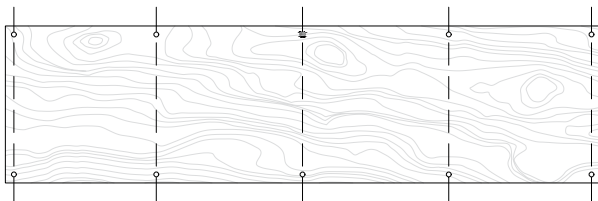
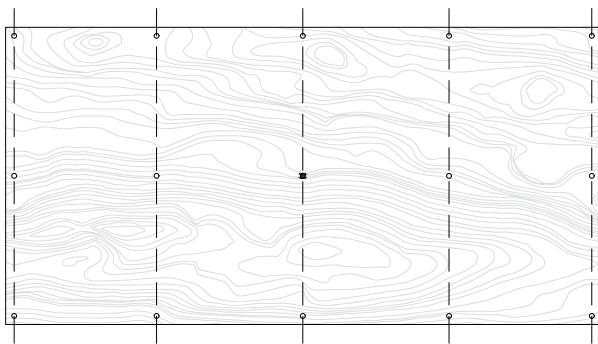

- Fixed Points
- Floating Points

Centering the screw / rivet

The screw / rivet must be centered in the hole to permit dimensional variations.

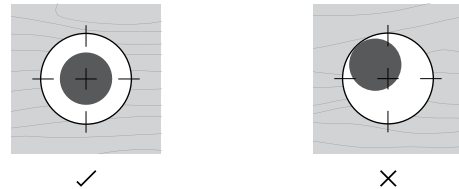

It is also very important for the fixing head to be completely parallel with the panel surface. Be sure that the head of the fastener doesn't make an excessive pressure on the panel and allows its movement due to dilatations. It is recommended the use of a depth locator during installation.

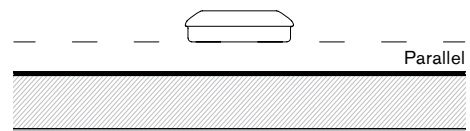

Panel Fixings

Facade may be installed using visible mechanical fasteners, such as screws or rivets lacquered in a shade similar to the panel veneer, offered by Parklex.

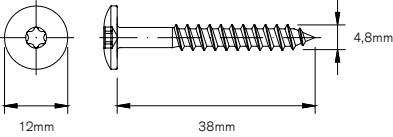
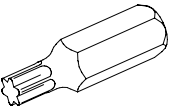
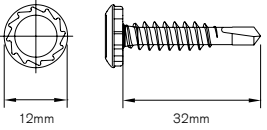
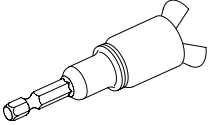
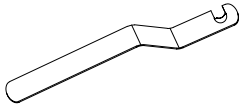
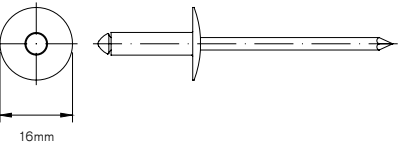
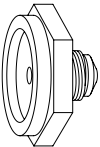
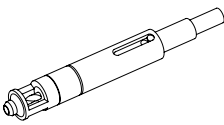
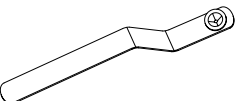
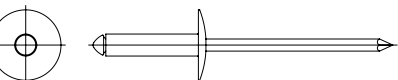
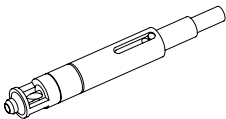
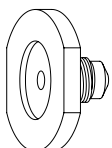
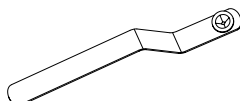
Fixing	Recommended installation tools		
<p>TWD-S-D12: Screw for fixing to timber battens Torx head.</p>  <p>12mm 38mm 4,8mm</p>	 <p>T20 W Adapter For TW-S screws with Torx head.</p>		
<p>SX3-L12: Screw for mounting on metal profiles. Irius head. Drill capacity in aluminum: max. 3mm and min. 2,5mm. Drill capacity in steel: max. 2mm and min. 1,5mm.</p>  <p>12mm 32mm</p> <p>A special screwdriver tip must be used in order to fix this screw.</p>	 <p>E420 Screwdriver For SX3 screws with Irius head.</p>  <p>SX Centering seat Ensures the concentric insertion of the screw to the panel, as well as its perpendicularity.</p>		
<p>AP16: Rivet for fixing to aluminum profiles. Assembly capacity: 18mm: 9,5-13,5mm.</p>  <p>16mm</p> <p>Other lengths may be available under request.</p>	 <p>AP Nozzle This is fitted into the riveter for rivet installation on floating points.</p>  <p>Centering seat with integrated bit Enables to perform the pre-drilling of the subframe concentrically to the wall.</p>  <p>ZL Centering seat Enables to perform the pre-drilling of the subframe concentrically to the wall.</p>		
<p>SSO-D15: Rivet for fixing to aluminium profiles in the event of applications located at a distance of ≤ 1 Km from the sea. Assembly capacity depending on the shaft length: 18mm: 8-12mm.</p>  <p>16mm</p> <p>Upon availability. / Other lengths may be available under request.</p>	 <p>Centering seat with integrated bit Enables to perform the pre-drilling of the subframe concentrically to the wall.</p>  <p>SSO-D15 Rivet Nozzle This is fitted into the riveter for rivet installation on floating points.</p>  <p>ZL Centering seat Enables to perform the pre-drilling of the subframe concentrically to the wall.</p>		

Screw / Rivet fixing details

- Screw

Metal profile

SX3-L12 (5.5 x 32)

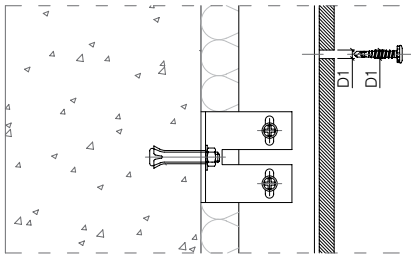

[Fixed point]

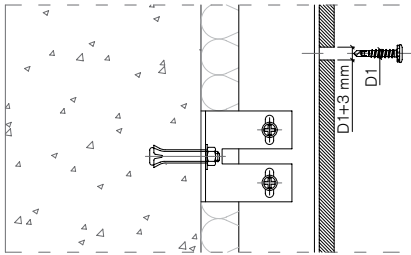

[Floating point]

D1. Screw diameter

- Rivet

Aluminum profile

AP16 (5 x 18)

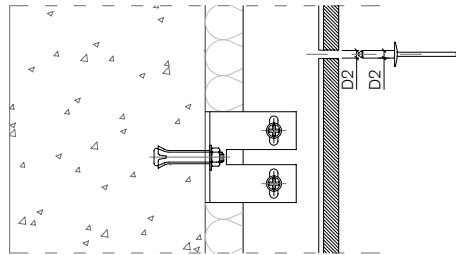

[Fixed point]

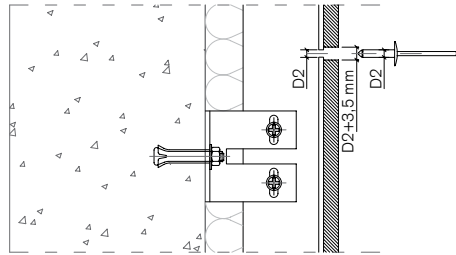

[Floating point]

D2. Rivet diameter

- Screw

Timber batten

TWS D12 (4.8mm x 38)

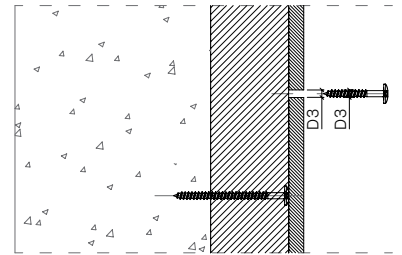

[Fixed point]

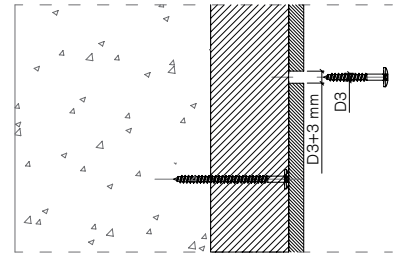

[Floating point]

D3. Screw diameter

Drilling

The Facade panels undergo dimensional variations due to temperature and humidity. These dimensional and structural variations must be taken into account when drilling holes. If using **screws**, the diameter of the hole must be 3 mm larger than the diameter of the screw shank, except at one point per panel, where the diameters will be equal (fixed point). This fixed point must be as close as possible to the center of the panel. If using **rivets**, the diameter of the hole must be 3,5mm larger than the diameter of the rivet shank, except at one point per panel, where the diameters will be equal (fixed point). As in the case of screws, the fixed point must be as close as possible to the center of the panel.

3.3.2. Fixing with plugs

Parklex offers plugs in the same finish as the Facade panels, for hidden fastening using caps measuring 14,25mm in diameter. This system may only be used with panels that are 10 or 12 mm thick, and must be inserted with great care.

Installation

To install the substructure (distance between fixings and screw distance from edges), follow the instructions in section 3.3.1. **Exposed screw or rivet fixing** (p. 27).

Panel Fixings

The choice of screw will depend on the kind of profile.

	Profile type	
	Metal	Wood
Screw	DIN 7504N	DIN 7505
Characteristics	cylinder head, self-tapping	cylinder head
Ø Screw	5,5mm	5mm
Ø Head	10,8mm	10mm
Length	32mm	30mm

Fixed point and floating point

The same specifications must be followed for the fixed point and floating point as indicated in 3.3.1. **Exposed screw or rivet fixing** (p.27).

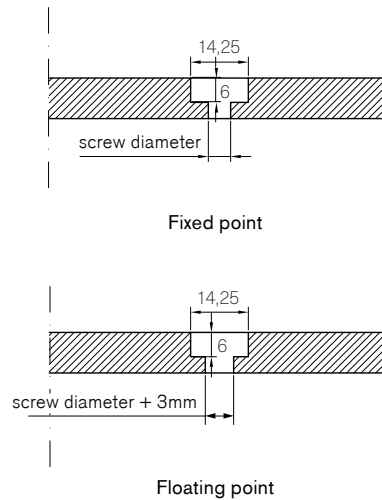

Parklex offers specific bits for pre-drilling the plug fixing system.

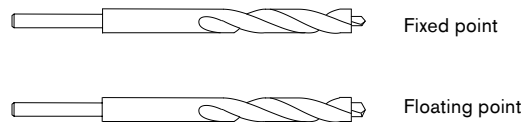

Plug installation

Once the panels have been fixed in place, the remaining cavity is filled with silicone sealant, leaving sufficient space to fit the 2mm plug. The screw must have a smaller head (2mm) than the hole diameter to allow for panel movement.

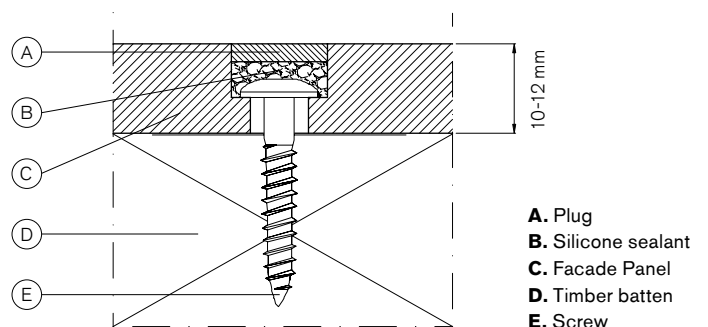

3.3.3. Hidden fixing with bracket hanging system

The bracket hanging system introduces the fixing bracket as the hidden mounting mechanical element. This system can only be used with panels 8, 10 and 12 mm thick.

Keep in mind the importance of a good layout. Parklex sells all of the parts required for hidden mounting with fixing brackets, such as special panel fixing profiles, brackets, milling screws, etc.

Distance between vertical profiles

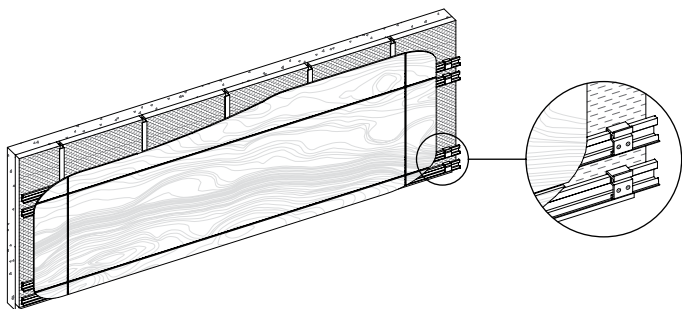

In this type of installation, there is a primary substructure of vertical profiles that create the necessary air chamber.

Thickness	Maximum distance
8, 10, 12 mm	1250mm

Distances between horizontal carrier rails

Carrier rails are installed horizontally to the front of the vertical profiles using 2 fixing screws installed diagonally to one another. The distance between the horizontal profiles must be $\leq 600\text{mm}$, with a minimum of three horizontal profiles for each panel.

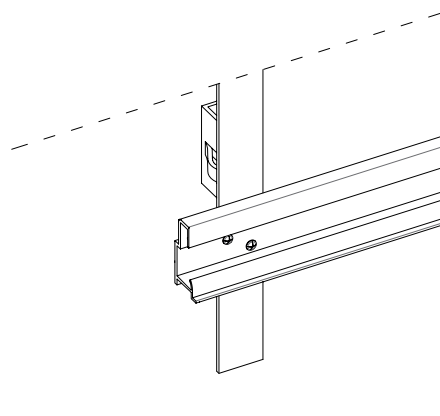

Installation with back fixed brackets and horizontal carrier rails

Fixing brackets are screwed to the rear of the panel. These panel fixing brackets are machined with an M8 metric hole at the top, which is used to adjust the height (using a bolt) or to lock them in place.

Parklex offers 2 screwing options:

Option 1: Hanging hooks fixing (TB-A2/TX-30)

Minimum board thickness of 10 mm. The fixing brackets are screwed to the rear of the panels using stainless steel milling screws ($\varnothing 6$ and 11.5 mm in length). A $\varnothing 5\text{mm}$ hole must first of all be drilled, slightly smaller than that of the screw, so that it will cut its own thread as it is screwed in place. This hole must be deeper than the insertion length of the screw to permit accumulation of the shaving created when carving. However, a margin of at least 2 mm must be left with respect to the exposed side of the panel.

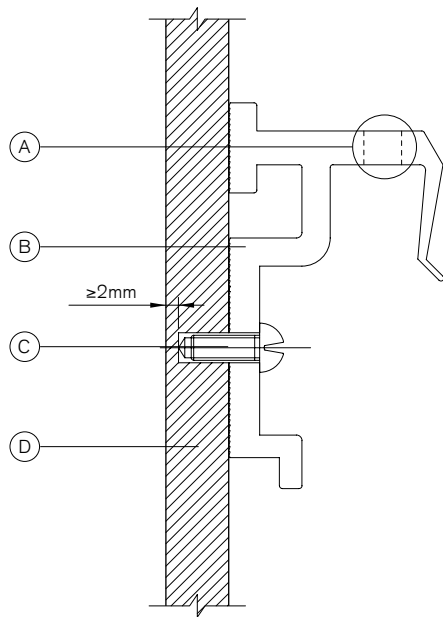

- A. Machined M8 hole
- B. Fixing bracket
- C. Milling screw
- D. Facade Panel

Taking care that the holes are clean and free of wood shavings, place the hanging hook in its place over the predrilled holes on the backside of the Facade panel and insert the TU-S fixing.

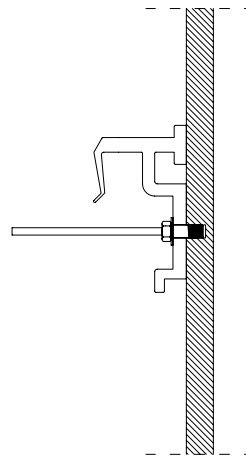

Remove completely the rivet mandrel with a riveter with a 17/32 or 17/40 nozzle (PowerBird or similar, for example) assuring that a slight perpendicular force against the surface is made during riveting operation.

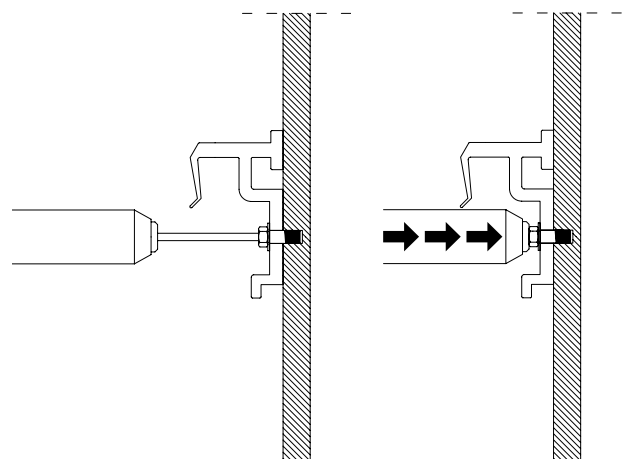

If TU-S fixing removal is needed, it is possible to unfix it with hexagonal head. For later installation of the hanging hook move it slightly horizontally, drill again the panel as described before and proceed to install the new TU-S fixings again. Do not use the original holes for new TU-S fixings.

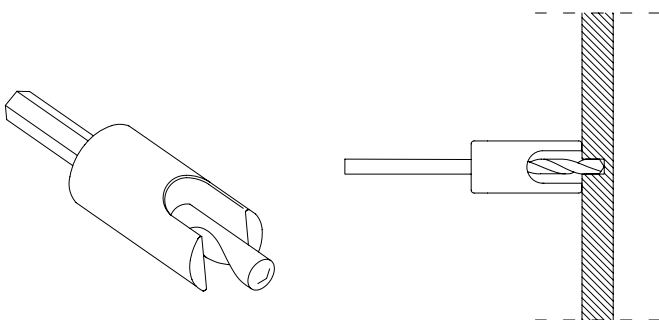

Option 2: Hanging hooks fixing (TU-S 6.0x11 mm)

Minimum board thickness of 8 mm. The hanging hooks are fastened to the back side of the panel using TU-S Ø6x11 mm fasteners. As the Facade material is very hard, a 6mm diameter perforation and a 6mm deep blind must be made before fastening the panel screw on the backside of the Facade panel. The perforation must be done with a computerized numeric control (CNC) machine or manually with a Parklex HSS-6.0x41 bit equipped with a Parklex depth stopper.

Distances between brackets

Thickness	Maximum distance
8mm*, 10mm	≤600mm
12mm	≤800mm

There must always be at least 3 panel fixing brackets in each direction for every panel. / * Only for screwing with Option 2.

Bracket distance from the panel edge

- A. Lateral edge distance
- B. Bottom edge distance
- C. Upper edge distance

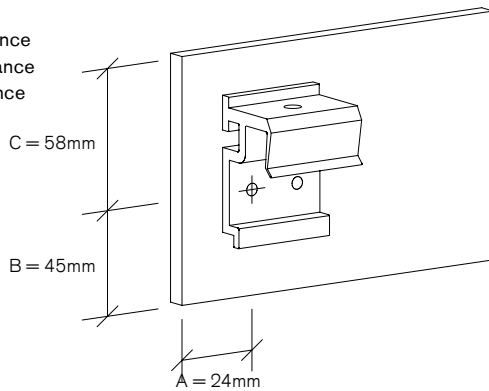

Fixing screw

Once the panels have been aligned in their final position with the help of the height adjustment screw, a stainless steel self-tapping screw fixes the bracket to the horizontal rail to prevent it from moving sideways along said rail. The central bracket of the top line of the panel must be screwed in place, as shown in the drawing.

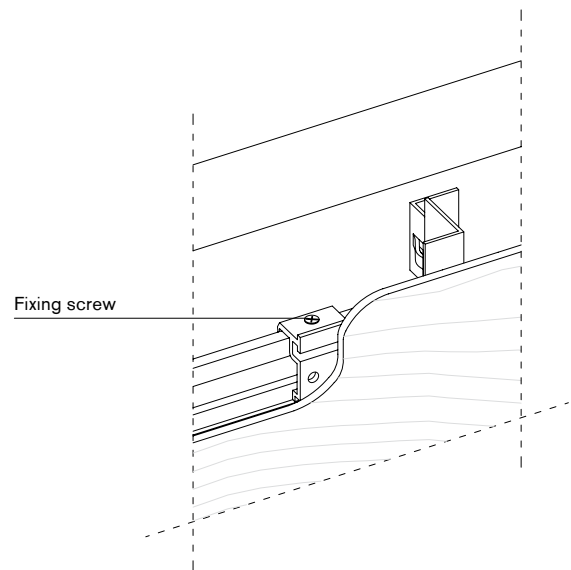

Height adjustment screw

For good alignment between the Facade panels, the first thing to use is the height adjustment screw. This screw enables you to correct small deviations in the panel horizontal installation line. Usually, only one screw per panel is required, which is fixed to one of the side brackets of the top line.

- A. Height adjustment screw
- B. Panel fixing bracket
- C. Horizontal carrier rail

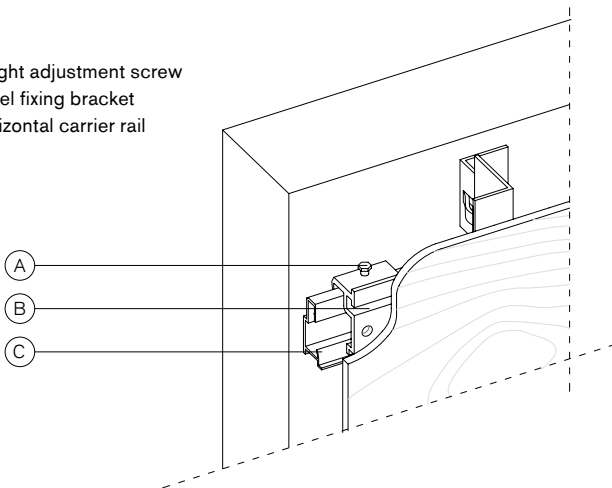

Example

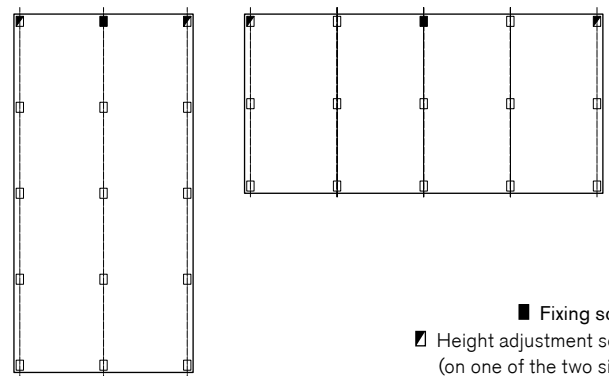

Maximum cantilever of the horizontal carrier rail

The maximum cantilever of the horizontal carrier rail must be controlled on corners and finishes to maintain their rigidity; the maximum cantilever distance is 120mm.

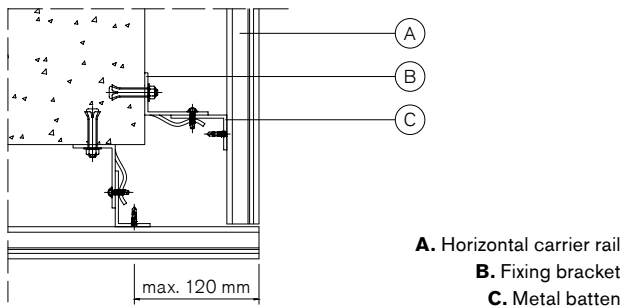

If this is not possible, the carrier rail must be reinforced using an angular profile as shown in the following image.

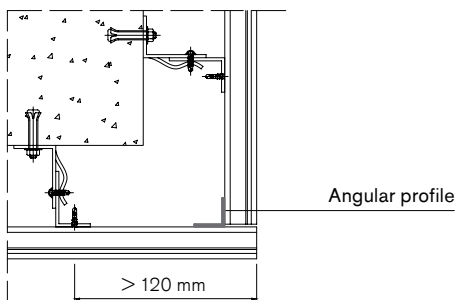

3.3.4. Hidden fixing with an adhesive system

Currently, Parklex has several certified processes for mounting Facade panels using structural adhesive systems. Due to the continuous variations that occur in adhesive system designs, as well as in their application procedures, we recommend that you contact Parklex for the application procedures currently in use. This system may only be used with panels that are 8, 10 or 12mm thick.

Distance between vertical profiles

In installations using adhesive systems, the distances between profiles must be reduced when compared to those using screws or rivets, in order to ensure good adhesive polymerization.

Thickness	Maximum distance
8 mm	400mm
10 / 12 mm	600mm

There must always be at least 3 fastening points in each direction for every panel.

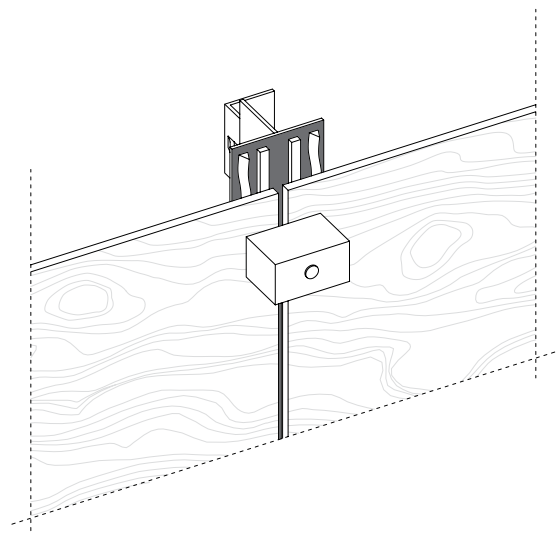

Clamps

Once Facade is installed using this system and until the adhesive polymerizes, clamps must be placed around the perimeter of the pieces (every 200-300mm), especially at the corners). It is essential that applying pressure beyond the thickness of the double-sided tape is avoided.

3.3.5. Hidden fixing with overlapping slats

Parklex has developed a Facade fixing system in overlapping slat format.

Two different widths of slat are supplied, 190 and 290 mm*, both in a maximum length of 2440mm. This hidden fixing system is only valid for 8mm panel thicknesses.

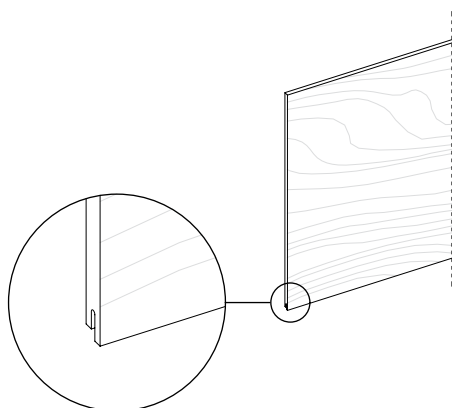

The slats are supplied with its longitudinal edge grooved.

* For other widths, contact Parklex technical department.

Distance between vertical profiles

The vertical substructure must be fitted in accordance with the specifications of section **3.2. Substructure** (p. 26). You must start from a standard vertical substructure:

Thickness	Maximum distance
8 mm	600mm

There must always be at least 3 fixing points in the longitudinal direction of the slat.

Anchoring pieces installation

The anchoring pieces, made in black-lacquered stainless steel, are fixed to the lower part of the vertical profiles.

Alignment between the anchoring pieces is important, since the panels will rest on these pieces.

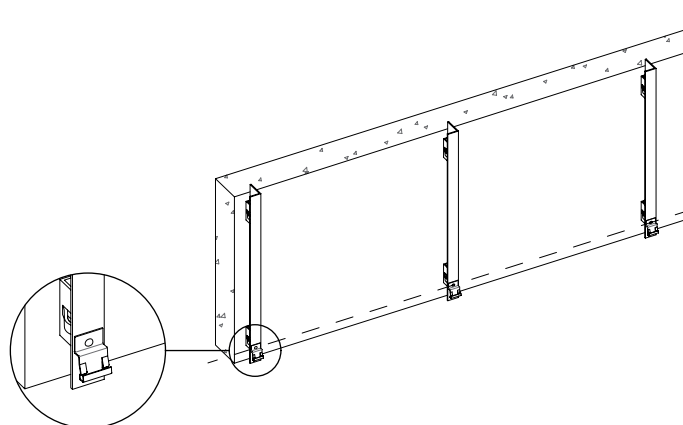

The correct screw choice will depend on the type of profile. For metal profiles, use screw DIN 7504N (black zinc-plated). For wooden profiles, use 7505N (black zinc-plated).

It is advisable to place an 8mm stud behind the anchoring pieces in the first row to act as a stop.

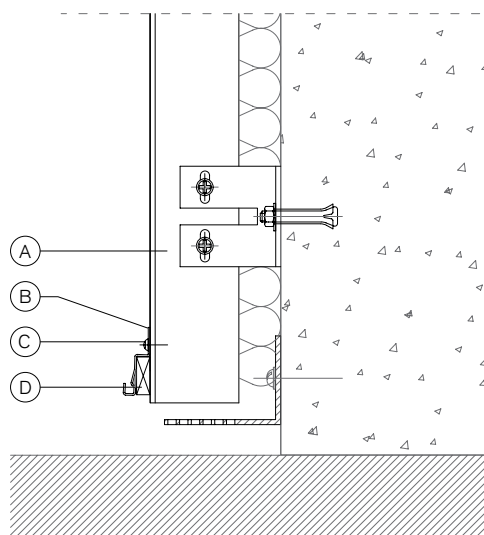

- A.** Vertical batten
- B.** Anchoring piece
- C.** Screw
- D.** Stud

Slat installation

Once the first row of anchoring pieces has been installed, add the first row of machined slats. The groove in the slats fits into the anchoring piece.

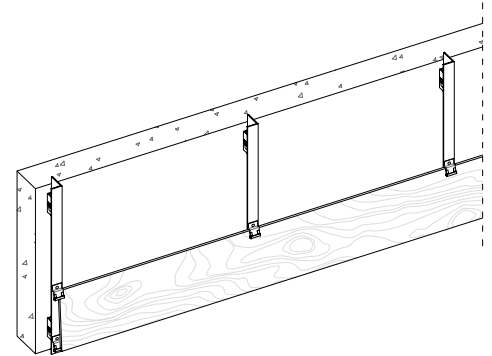
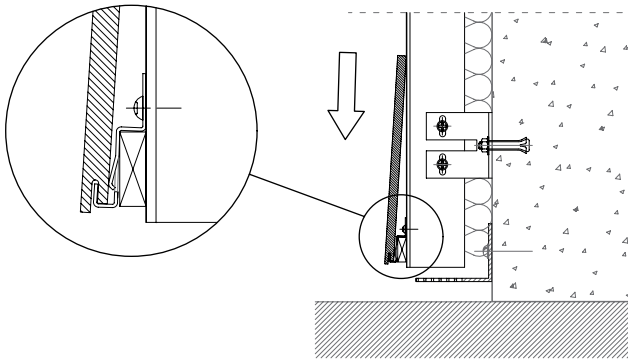

To finish off, fix the last row of slats in place using Parklex lacquered screws. See section **3.3.1. Exposed screw or rivet fixing** (p. 27) for Distances between fixings, Distance from the edges, Fixed Point and Floating Point and Panel fixings.

The panels are joined with the same anchoring piece, since thanks to its surface it can support two panels, leaving the necessary joint between them.

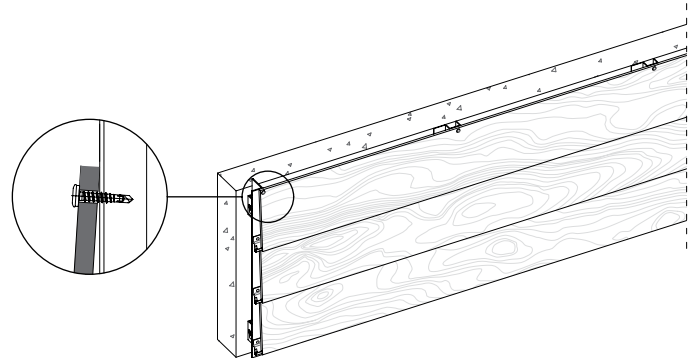
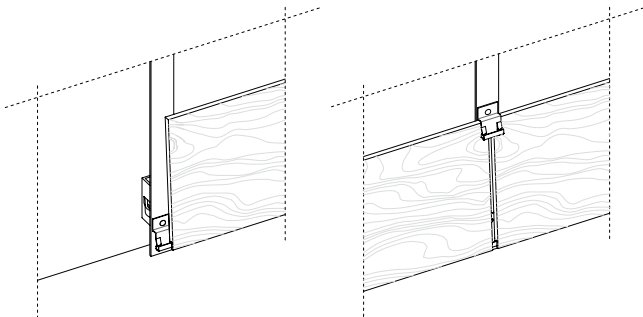

Top fixations with typical Parklex screws

The second row of anchoring pieces is fixed to the top of the first panel, and the second row of slats fitted into them, and so on.

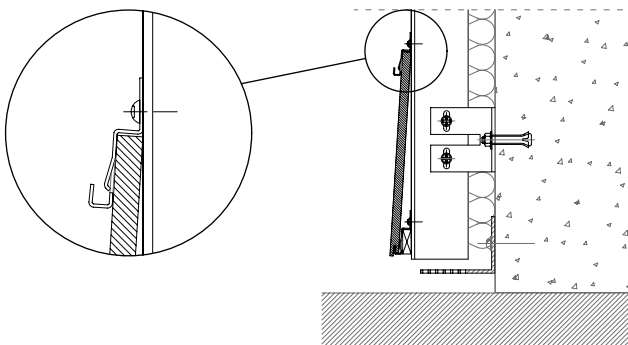

Three installation patterns: The overlapping American slats system permits different patterns with no need to change the position of the profiles or the pieces, provided that the space between profiles is 600mm.

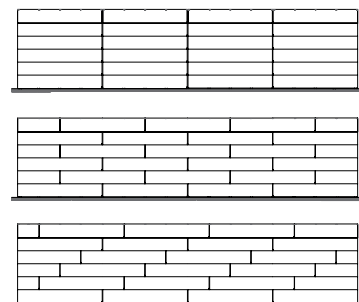

3.4. Installation details

3.4.1. Window details

Exposed screw or rivet fixing

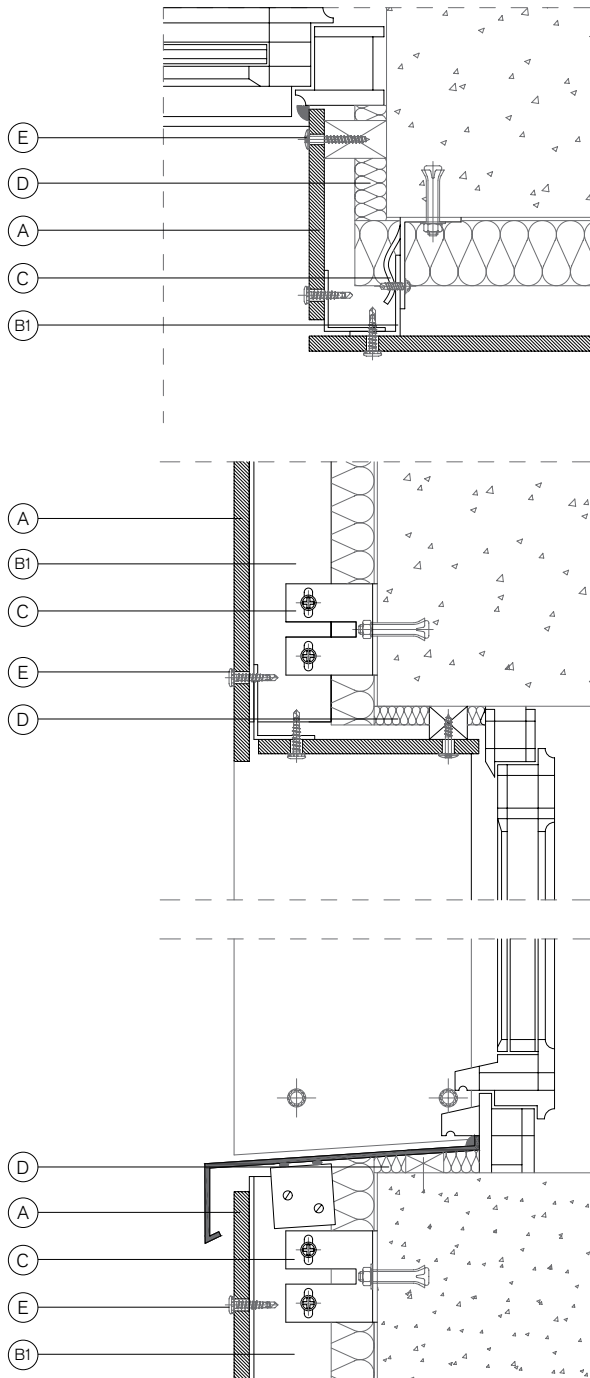

Hidden fixing with bracket hanging system

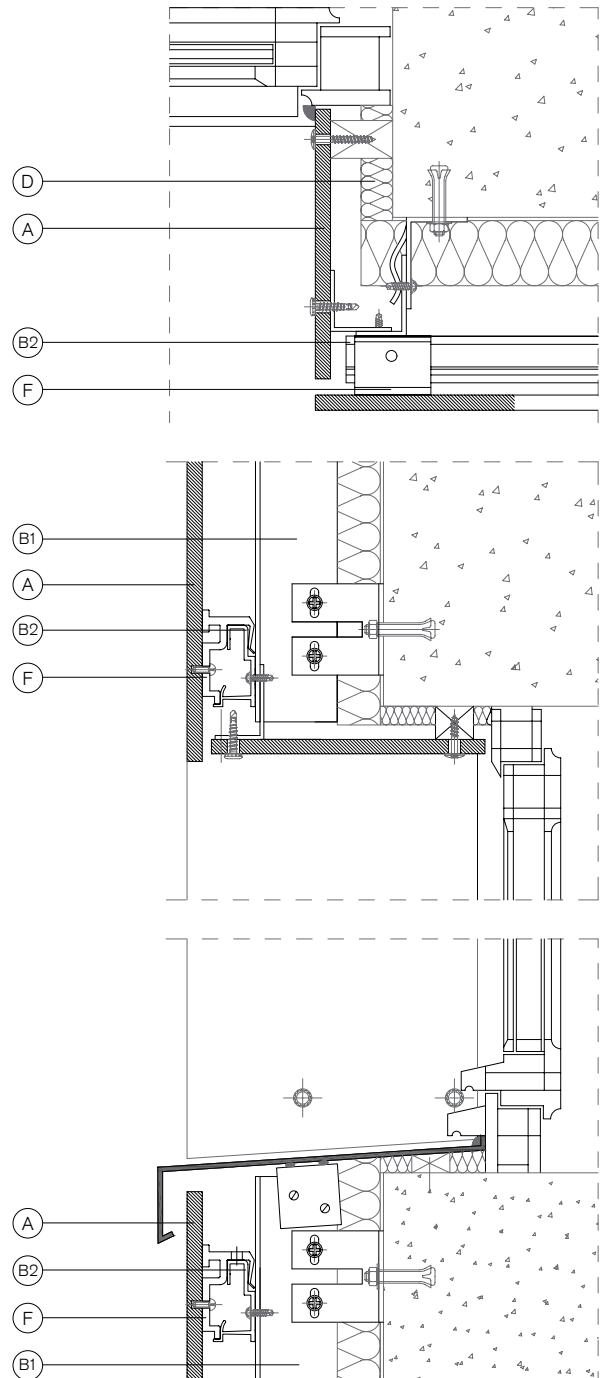

- A.** Facade panel
- B1.** Aluminum profile
- B2.** Horizontal carrier rail
- C.** Fixing bracket
- D.** Isolation
- E.** Screw
- F.** Panel fixing bracket

3.4.2. Corner details

Mitered corner

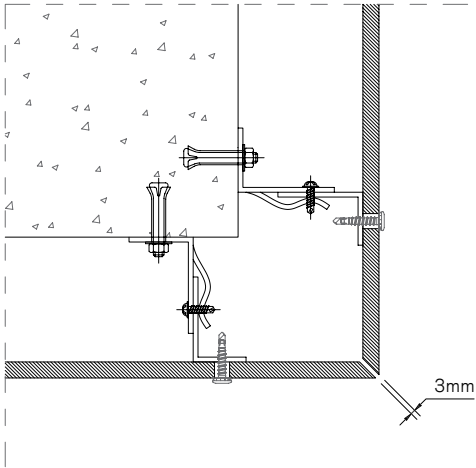

Pilaster edges

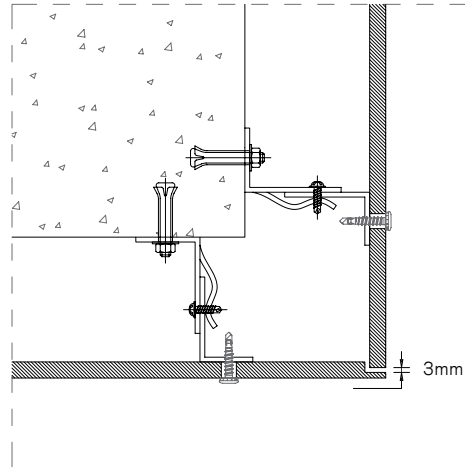

Overlapping edges

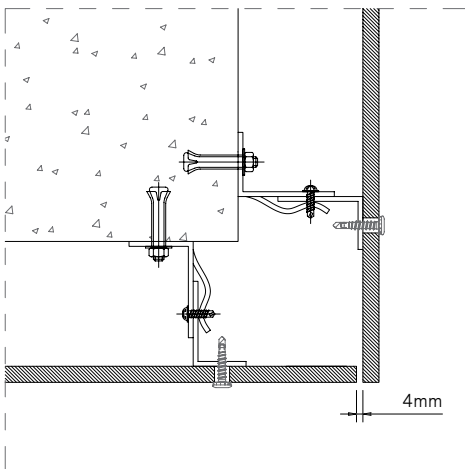

Interior pre-curved corner

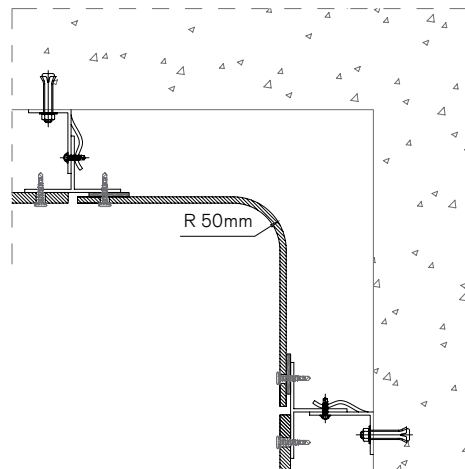

Overlapping edges with reinforced corners

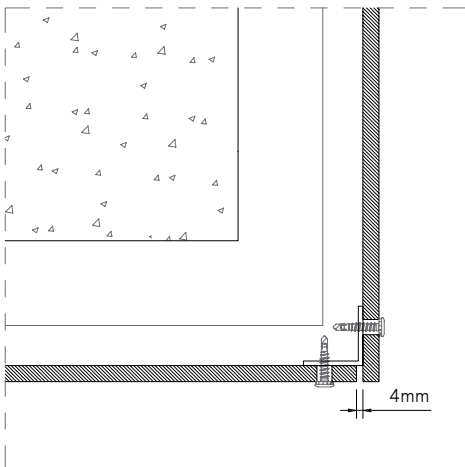

Exterior pre-curved corner

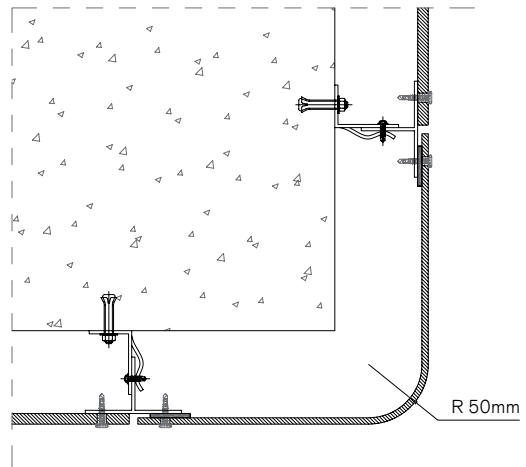

4. Louvre installation system

4.1. Static louvres

For projects with solar and energy incidence control requirements, Parklex has developed a static louvres system.

This system permits the installation of $\geq 10\text{mm}$ thick Facade panel slats as static louvres, at 0° , 30° and 60° in both the horizontal and vertical directions.

Parklex supplies the slats in 3 different widths: 86, 94 and 114mm^* , with a maximum slat length of 2440mm .

*For other widths, contact Parklex technical department.

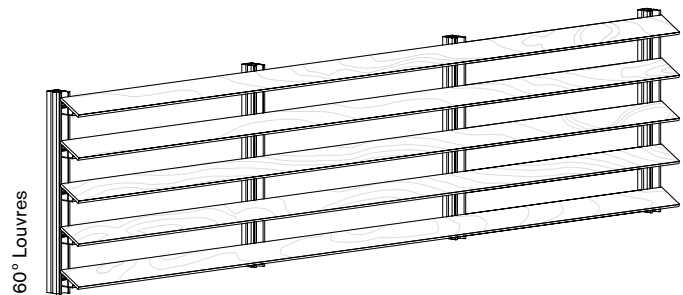
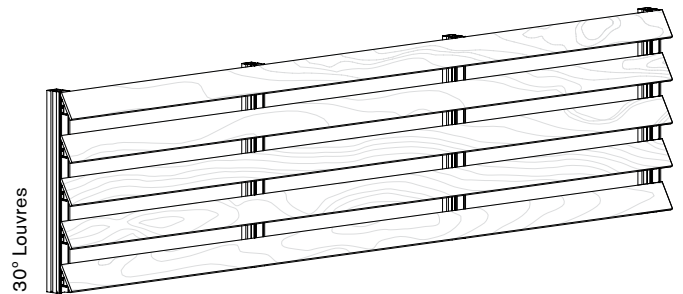
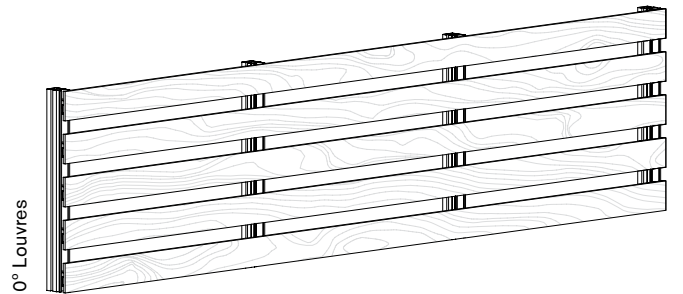

4.1.1. Substructure

The first step is to install the profiles with trim to which the louvres will be fitted. To fix these profiles to the wall, Parklex supplies brackets for absorbing irregularities in the façade.

The direction of the substructure installation (vertical or horizontal) will determine the kind of louvre to be installed. Vertical profiles for horizontal louvres and horizontal profiles for vertical louvres (provided that ventilation is guaranteed).

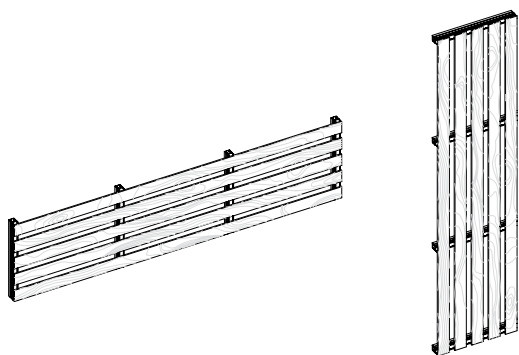

The substructure alignment is particularly important, given that any imperfection or unevenness would be transferred to the louvre.

Thickness	Maximum distance
10mm	800 mm

There must always be at least 3 fixing points in the longitudinal direction of the slat.

4.1.2. Substructure installation

The profiles with trim are perforated every 20 mm*, making it possible to adjust the louvre design to the needs of each project.

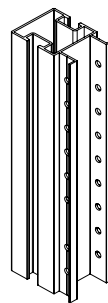

*For other trim distance, contact Parklex technical department.

Once the profiles have been installed, each base piece is held in place at the desired profile level using two stainless steel self-tapping screws (one on each side).

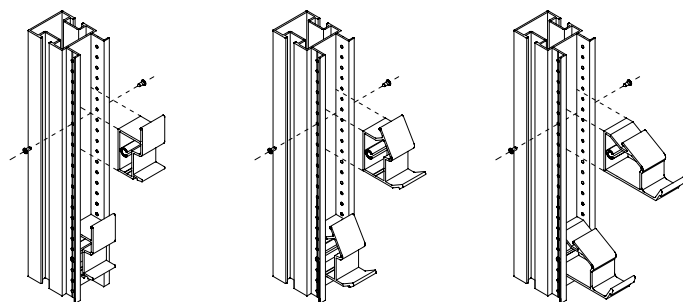

Installation of 0° Louvre base piece

Installation of 30° Louvre base piece

Installation of 60° Louvre base piece

To join the panels, larger-sized bases should be used.

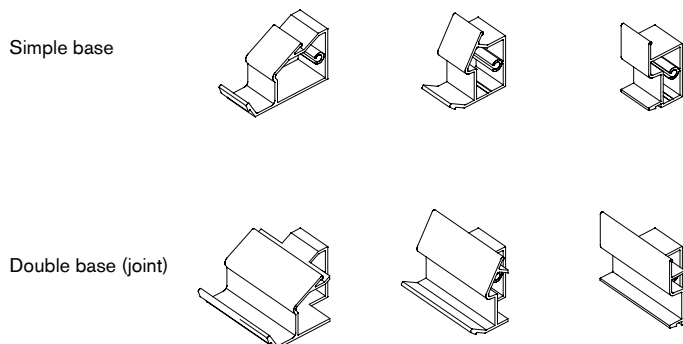

4.1.3. Supporting clip installation

Clip selection

Parklex supplies fixed and floating clips. All clips screwed to the rear part of the Facade slats must be floating, except for one per slat, which must be fixed. This fixed point must be as close as possible to the center of the slat.

Distance from the edges

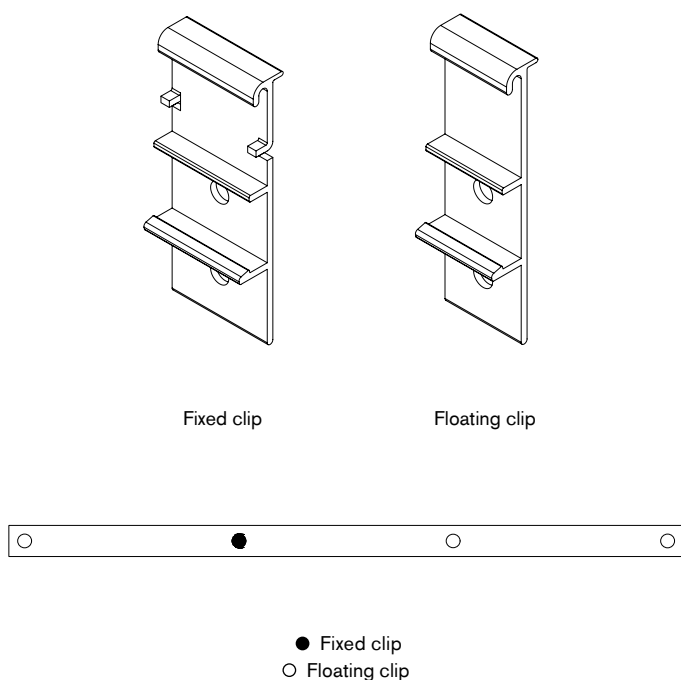

The distance between the edge of the slat and the screws (screwed to the rear of the slat) must be 15 ± 2 mm.

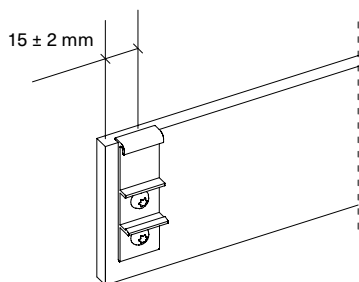

Fixing the clip

The clips are fixed to the rear of the panel using stainless steel milling screws ($\varnothing 6$ and 9,5mm in length). To do this, first of all drill a hole $\varnothing 5$ mm in diameter, slightly smaller than that of the screw, so that it will cut its own thread as it is screwed in place. This hole must be deeper than the insertion length of the screw to permit accumulation of the shaving created when carving. However, a margin of at least 2 mm must be left with respect to the exposed side of the panel.

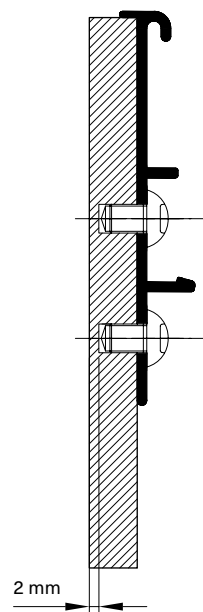

4.1.4. Louvre installation

Once the profiles and fastenings have been installed, simply fit the louvre onto the substructure installed.

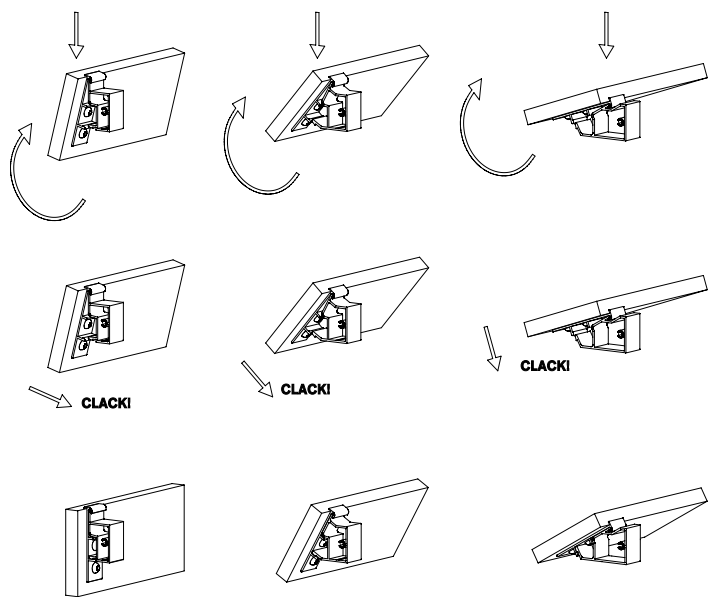

For joints between slats, the clips at the ends of each one are fitted onto the special base for joints, leaving a gap of $\geq 6\text{mm}$.

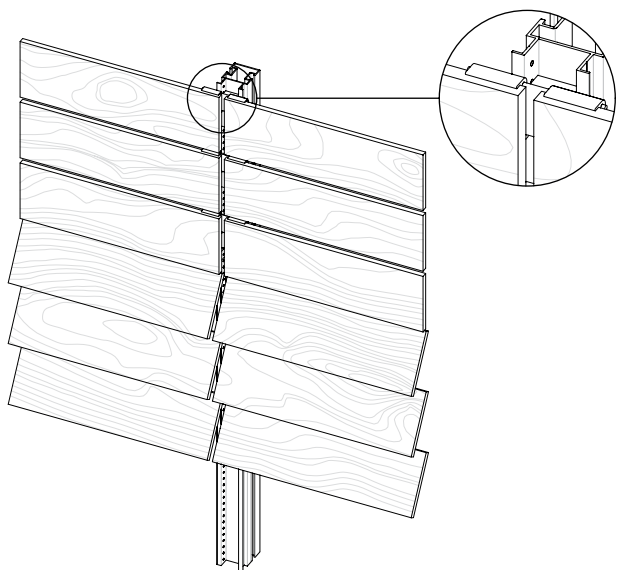

5. Dropped ceiling installation system

5.1. Fixing the dropped ceiling

Facade panels can be installed on dropped ceilings.

In dropped ceiling installation systems a minimum space of 20 mm must be left around the perimeter to permit ventilation through the chamber

5.1.1. Screw or rivet fixing

To install Facade panels in dropped ceiling mode with the exposed fixing system, you must pay attention to the instructions described in section **3.3.1. Exposed screw or rivet fixing** (p. 27). This fixing system can be used with 8, 10 and 12mm panels.

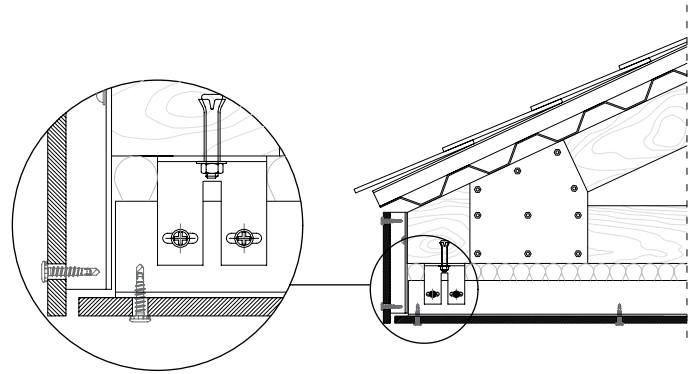

Distance between profiles

Thickness	Maximum distance
8 mm / 10 mm	600 mm
12 mm	800 mm

There must always be at least 3 fastening points in each direction for every panel.

5.1.2. Fixing with plugs

This system permits the installation of boards 10 and 12mm thick as dropped ceilings. To install Facade boards as a false ceiling by means of fixing with plugs, it is essential to consult the instructions described in section **3.3.2. Fixing with plugs** (p. 31).

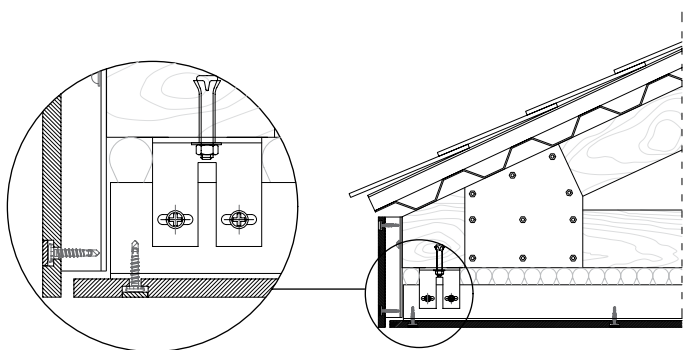

5.1.3. Hidden fixing with bracket hanging system

This system permits the installation of boards with a thickness of 8, 10 and 12mm as dropped ceilings. To install Facade boards as false ceiling using hidden fixing brackets, it is essential to consult the instructions described in section **3.3.3. Hidden fixing with bracket hanging system** (p. 32).

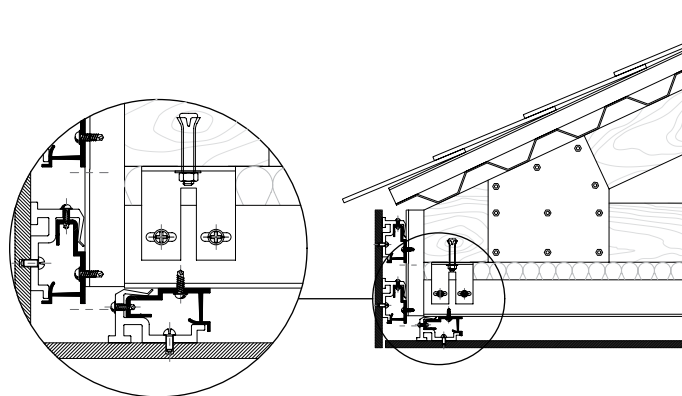

Distance between profiles

Thickness	Maximum distance
10 mm	600 mm
12 mm	800 mm

There must always be at least 3 fastening points in each direction for every panel.

Panel fixing

Once the pieces have been aligned in their final position, a stainless steel self-tapping screw fixes the bracket to the horizontal rail to prevent it from moving sideways along said rail. The central bracket of the top line of the panel must be screwed in place.

Distance between profiles

Thickness	Maximum distance
8 mm / 10 mm	600 mm
12 mm	800 mm

There must always be at least 3 fastening points in each direction for every panel.

6. Installation system in curves

6.1. Panel curving

Thanks to the flexibility of wood fibers, we can adapt the Facade panels to certain curvature radii, whether they are concave or convex.

Parklex offers two different solutions for projects requiring the installation of Facade as curved façade cladding; by means of standard panels if the intention is to achieve radii greater than 3 m, or by means of pre-curved panels if the intention is to achieve smaller radii.

**Each radius requires a specific panel thickness. In the event of wanting to use thicknesses other than those detailed below, consult the Parklex technical department.*

The Facade panels are flat and rigid; however, they can be curved to achieve certain curvature radii. The curvature radius will depend on the thickness of the material. The thinner the material, the tighter the curves, in other words, the smaller the radius.

As seen in the table, when installing the panels on a curved structure, the distance between vertical profiles must be reduced. The distance between the fixing point to the edge must also be decreased. This distance must be between 20 and 25mm. This table is valid only for curving in the grain direction*. **Panels may only be installed through an exposed mechanical system using screws or rivets.**

*For panel curving in the crossgrain direction, please contact Parklex technical department.

Curvature radius	Thickness to use	Distance between carrier rails
≥3m	6mm	≤300mm
≥10m	≤8mm	≤400mm
≥20m	≤10mm	≤450mm

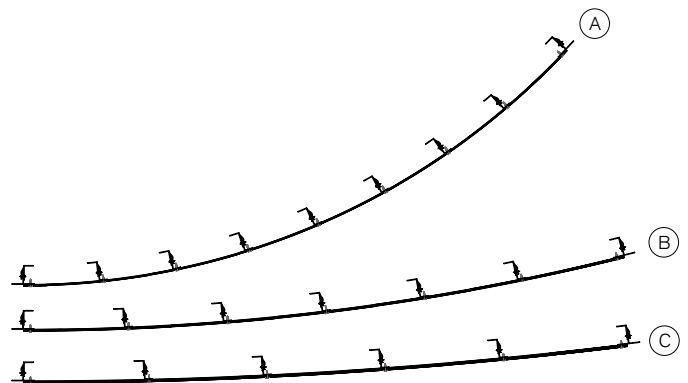

- A. 6mm thick: radius from 3 to 10 m
- B. 8mm thick: radius from 10 to 20 m
- C. 10mm thick: radius ≥ 20 m

6.2. Pre-curved panels

Parklex has developed pre-curved Facade panels supplied curved in different radii depending on the project requirements. The pre-curved Facade panels are supplied in a thickness of 6mm and their dimensions vary according to the chosen grain direction. The available radii are 0,33m, 0,5m, 1m, 2m and 4m and they can be adapted to suit specific curvatures on site at a later date.

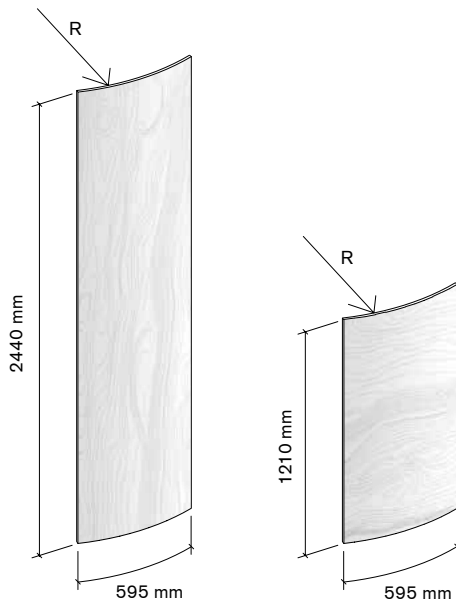

For other pre-curved Facade panel development dimensions, please contact Parklex technical department.

6.3. Installation of pre-curved panels

6.3.1. Exposed screw or rivet fixing

The pre-curved Facade panels can only be installed using exposed lacquered screws or rivets in the same colour as the panel.

Selection of the pre-curved Facade panel

To select the correct pre-curved panel, consideration must be given to the direction of the grain, the curvature radius of the area where the installation will take place and whether the panels require concave or convex curving, as shown in the drawing.



To select the pre-curved Facade curvature radius, consideration must first of all be given to the curvature radius of the area to be clad. The curvature radius of this area does not need to match the standard radius selection offered. In such cases, use a standard panel radius, the one nearest the building curvature radius, always selecting the one bigger than it. For their installation, you must pay attention to the instructions described in section 3.3.1. Exposed screw or rivet fixing (p. 27).

Example: Curved area radius: 1500mm → Pre-curved Facade panel radius: 2000mm

Note: In cases where the radius of the piece is slightly greater than the area to be clad, select one closest to it.

Example: Curved area radius: 1100mm → Pre-curved Facade panel radius: 1000mm

Given that the panel curvature radius will be greater than that of the building, each piece must have an intermediate profile support, as shown in the image.

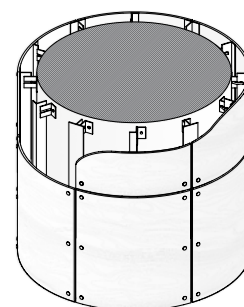

6.4. Technical datasheet

Tests	Standard	Property or attribute	Measurement unit	Results
				Parklex Facade Curved Rev: 04 (06.2016) REF: FTFACADEC
1. Inspection requirements				

Colour, pattern and surface finish	EN 438-8 Part 5.2.2.3	Due to the fact that wood is a natural product, each veneer may be considered as unique. Colour and structure differences are considered as normal. Singularities such as knots and resin inclusions are not considered as defects, but as a part of the décor. There are differences in light fastness performances depending on the wood species and the source of the wood.		
------------------------------------	-----------------------	--------------------------------------------------------------------------------------------------------------------------------------------------------------------------------------------------------------------------------------------------------------------------------------------------------------------------------------------------------------------------------	--	--

2. Dimensional tolerances

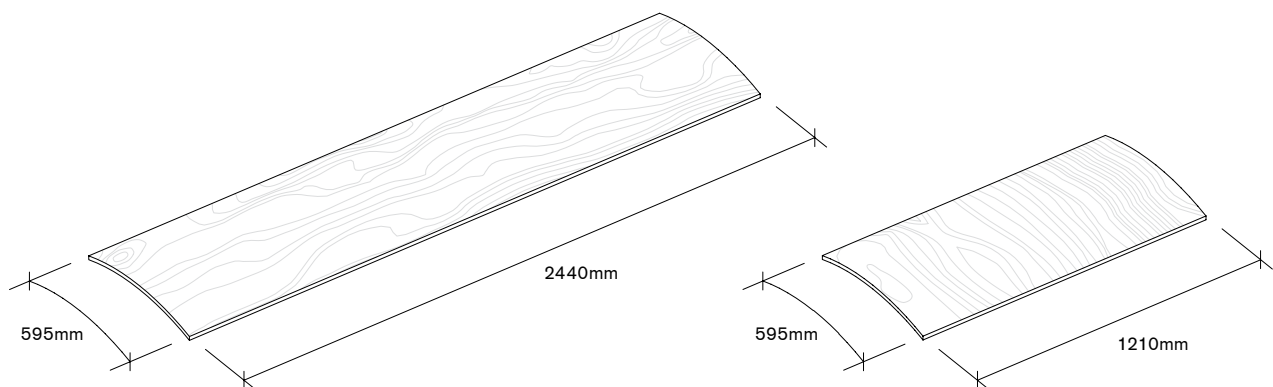

Thickness	6	mm	± 0,4
Curvature radius	330	mm	± 10%
	500		± 10%
	1.000		± 10%
	2.000		± 10%
	4.000		± 10%
Length and width	2440 x 595	mm	+10 / -0
	595 x 1220		+10 / -0

3. Physical properties

Resistance to impact with large diameter ball	EN 438-2 Part 21	Maximum height for which no visible surface cracking or imprint greater than 10mm	mm	≥ 1.800
Determination of graffiti resistance	ASTM D 6578:2000	Cleanability level	Permanent blue marker	4
			Spray red paint	4
			Wax black crayon	1
			Water based black marker	2

4. Weather resistance requirements

Resistance to UV light	EN 438-2 Part 28 Rating according to EN 20105 – A02	Contrast	Grey scale rating	≥ 3
		Aspect	Rating	≥ 4
Resistance to artificial weathering (including light fastness)	EN 438-2 Part 29 Rating according to EN 20105 – A02	Contrast	Grey scale rating	≥ 3
		Appearance	Rating	≥ 4

5. Safety requirements

Water vapour permeability	EN 438-7 Part 4.4	Wet cup method	μ	110
		Dry cup method		250
Resistance to fixings	EN 438-7 Part 4.5	Screw holding value t ≥ 6mm	N	> 2.000
Density	EN ISO 1.183	Density	g/cm ³	≥ 1,35
Resistance to wet conditions	EN 438-2 Part 15	Moisture absorbed	%	≤ 5
		Appearance	Rating	≥ 4

6. Reaction to fire

Reaction to fire	EN 13.501-1	Euroclass	Classification	D-s2,d0 ⁽¹⁾
------------------	-------------	-----------	----------------	------------------------

(1) CWFT: Classified Without Further Testing according to EN 438 Part 7, 4.2.3.

Screw or rivet fixing is recommended. Other fixing systems must be consulted with our technical department.

www.parklex.com